

**Type F —
Series 101**

**48 Contact Male
Connectors**

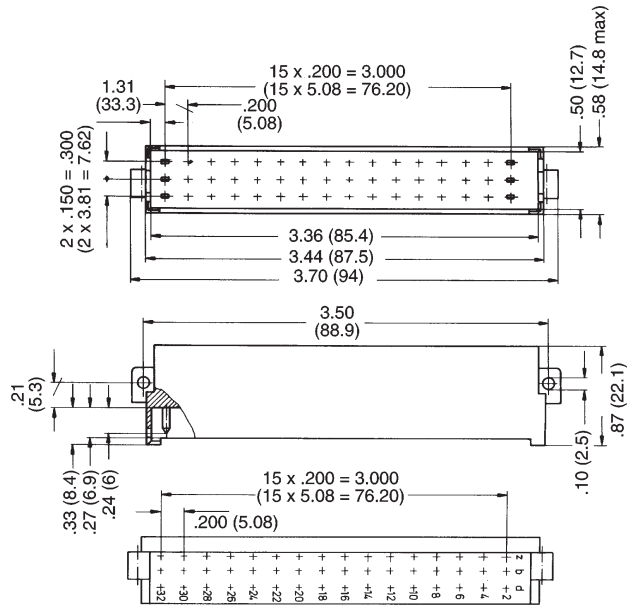

Dip Solder

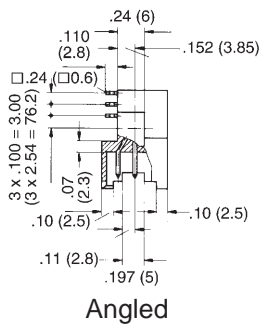

Printed Circuit Layout

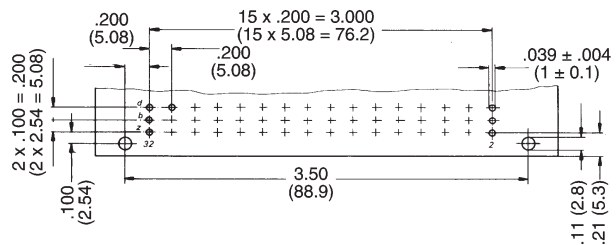

Part Numbers

No. of Contacts	Contact Arrangement	Performance Level	Termination Methods
			
48	Fully Equipped	2	101-048-033
		3	101-048-053

**Type F —
Series 101**

**48 Contact Female
Connectors**

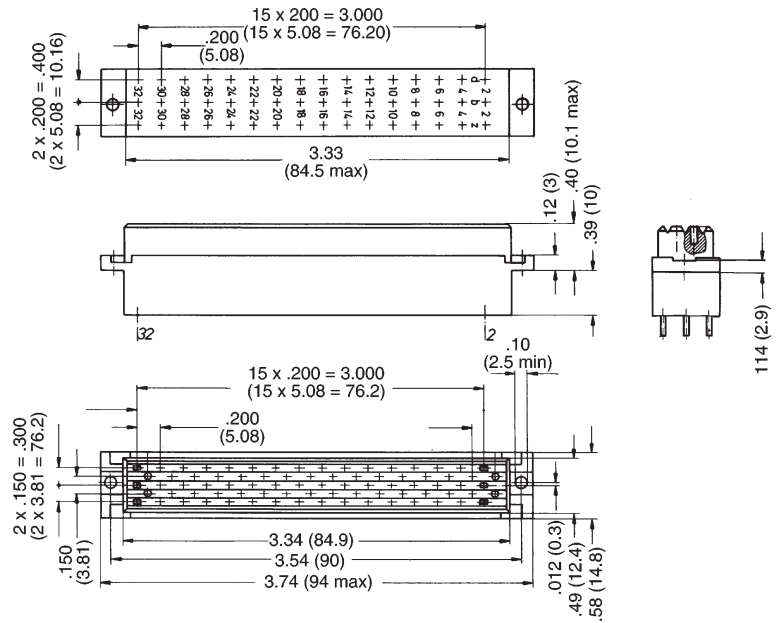

Printed Circuit Layout

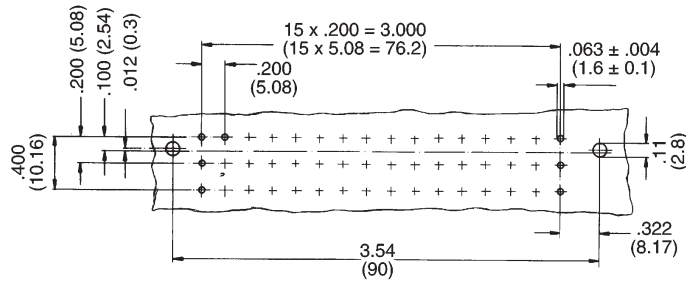

Part Numbers

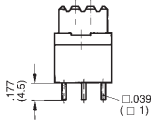
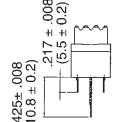
No. of Contacts	Contact Arrangement	Performance Level	Termination Methods	
				
48	Fully Equipped	2	101-048-438*	101-048-435*
		3	101-048-458	101-048-455

* Contact Factory for Availability